

SECOMAK
a i r a t w o r k



Process Heaters and Fans

PROCESS AIR HEATERS

SECOMAK have been producing specialist equipment for the provision of hot air for industrial processes for over sixty years and as a result have developed a unique range of heaters for use with their own blowers or independently.

To assist with the selection of the correct heater for given temperature and air volume requirements, SECOMAK have reproduced here the specially prepared Heat Transfer Curves used by their own engineers.

To use the curves, first select the required air flow rate and then the desired heater outlet temperature, where the axis cross read off the required heater size.

When used in conjunction with individual product data sheets, it will enable the specifiers to choose the most suitable combination of size, loading and air volume potential applicable to the application. Suitable fans together with accessories for the connection and control of SECOMAK heaters are available on request.

When using Heat Transfer Curves due allowance should be made for losses which will depend on the distance from the heater outlet and degree of insulation.

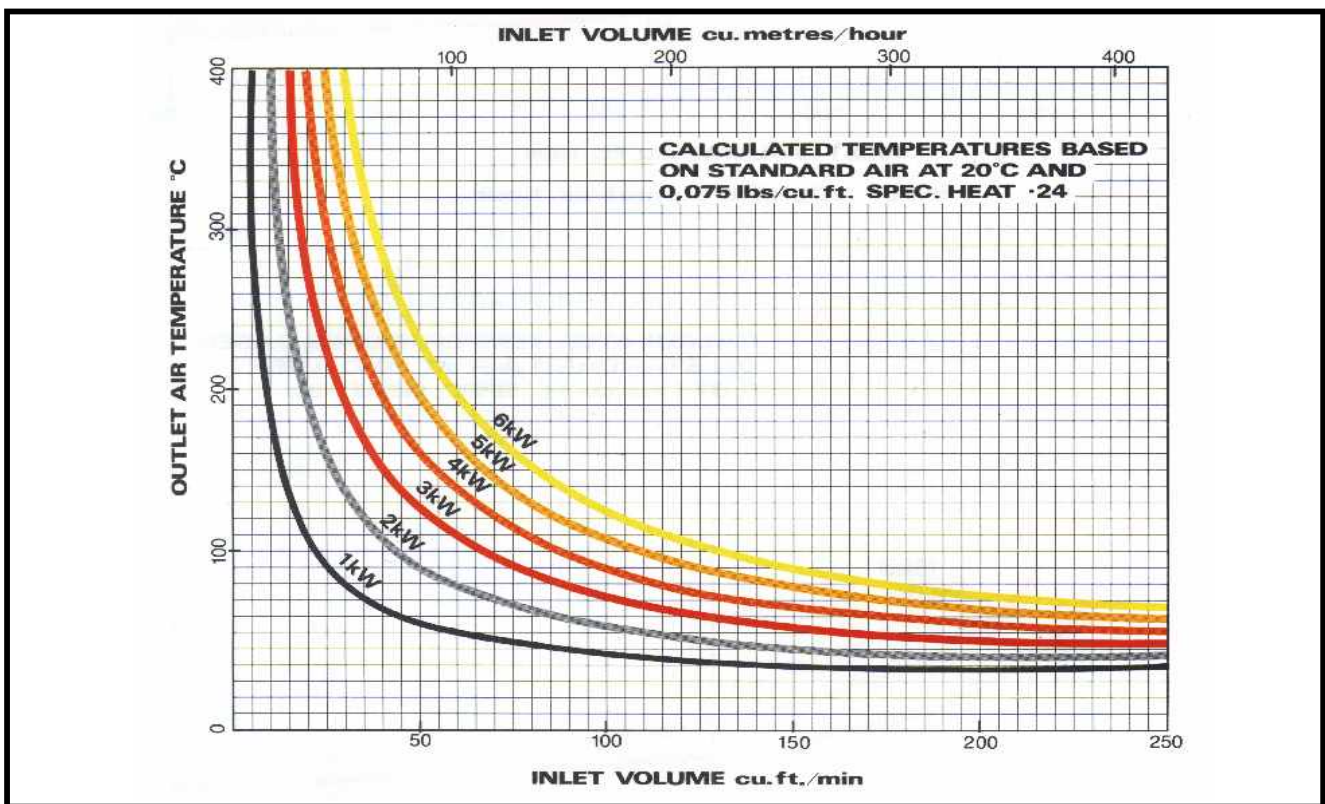

PROCESS AIR HEATERS

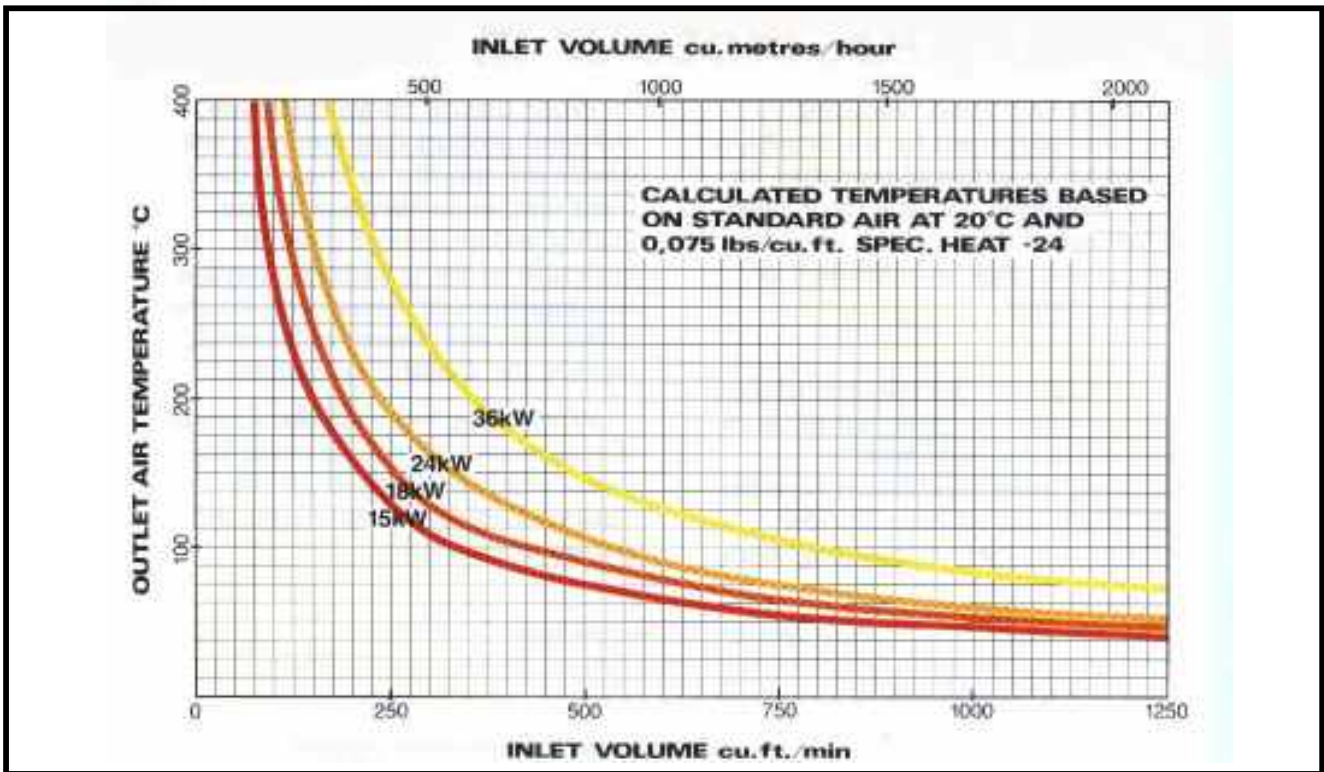
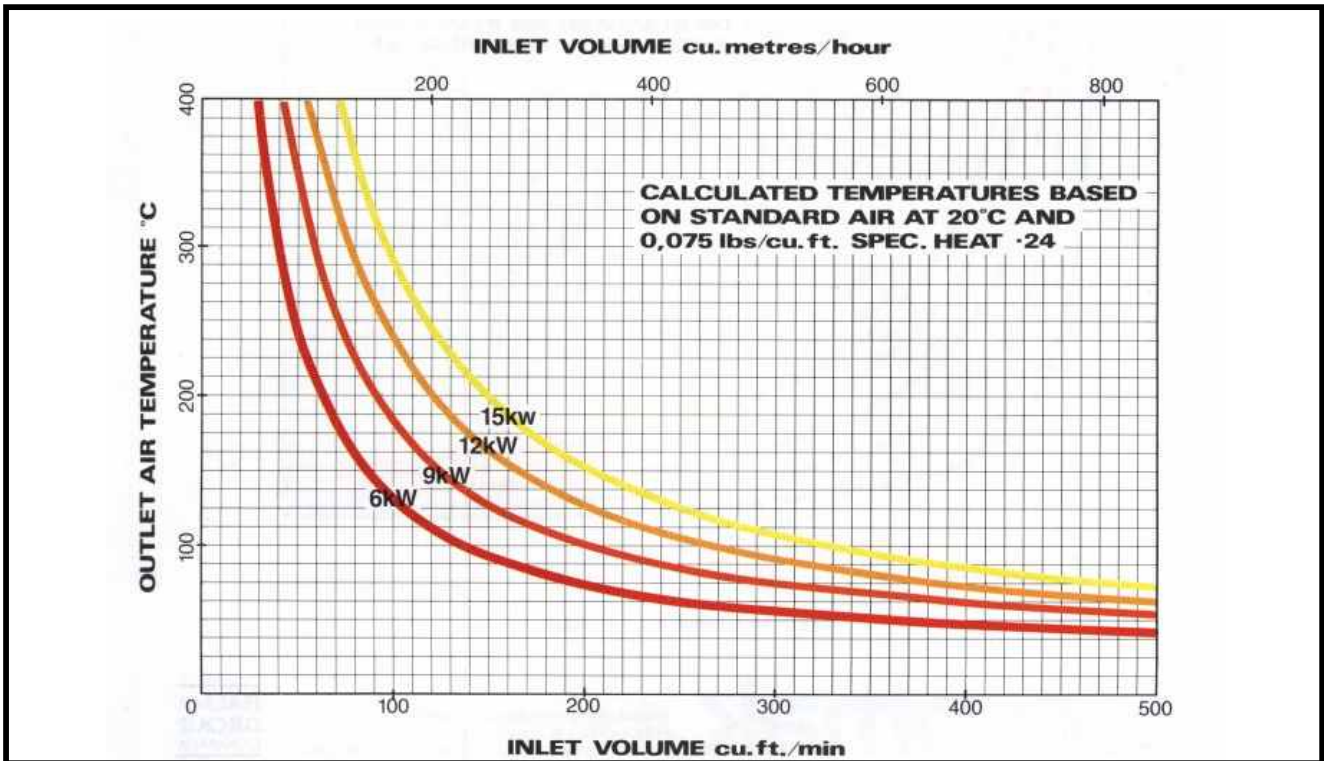

PROCESS AIR HEATERS



The Model 571 Heater consists of a single element assembly mounted inside a nickel plated casing. The casing is provided with a flanged inlet and the outlet can either be fitted with a flange or nozzle. The Model 571 will give an outlet temperature up to 300°C and is available in loading from 0.5kW to 3kW. The inlet of the Model 571 can be fitted with a thermal cut-out to protect the element in the event of the air flow becoming restricted. A variety of temperature controls are available ranging from switching devices to provide fixed loadings through to systems to monitor and regulate the outlet temperature.

Accessories available include an air regulating valve and hose adapter. The Model 571 will fit directly to the outlet of SECOMAK fan Models 573 and 575. Adapters are available to fit other fans in the SECOMAK range.

Available versions of Model 571 Heater

| Reference | 571/1 | 571/2 | 571/3 | 571/4 | 571/5 | 571/6 | 571/7 | 571/8 |
|---|-------|-------|-------|-------|-------|-------|-------|-------|
| AC only loadings: 2kW : 3kW with thermal cut-out | ■ | | | ■ | ■ | | ■ | |
| AC / DC loadings: 1 : 2 : 3kW without thermal cut-out | | ■ | ■ | | | ■ | | ■ |
| Single heat connected | ■ | ■ | | | ■ | ■ | | |
| 3 – heat connected (series parallel) | | | ■ | ■ | | | ■ | ■ |
| Flanged outlet | ■ | ■ | ■ | ■ | | | | |
| Conical outlet 1¼" dia. | | | | | ■ | ■ | ■ | ■ |

| Electrical: | Voltage ranges and loading |
|----------------|----------------------------|
| 230/250V AC | 2 or 3kW |
| 230/250V AC/DC | 1, 2 or 3kW |
| 200/220V AC | 2 or 3kW |
| 200/220V AC/DC | 1, 2 or 3kW |
| 100/110V AC | 2kW |
| 100/110V AC/DC | 1 or 2kW |

| Maximum Outlet Temperature: 300°C |
|---------------------------------------|
| Resistance to Airflow (approx.) |
| 0.5" w.g. at 40 ft ³ /min |
| 3.3" w.g. at 100 ft ³ /min |
| 7.4" w.g. at 150 ft ³ /min |

PROCESS AIR HEATERS

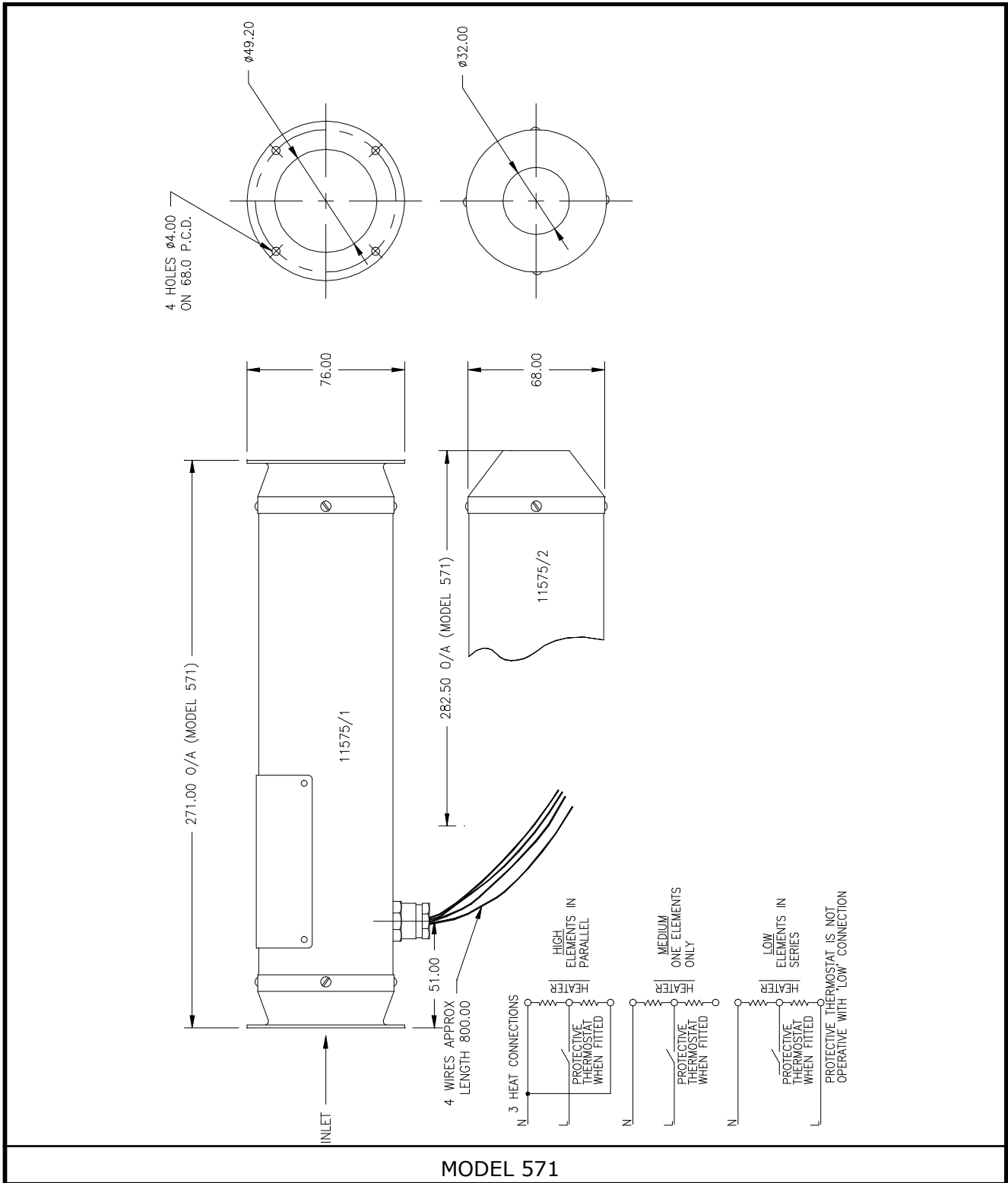

PROCESS AIR HEATERS

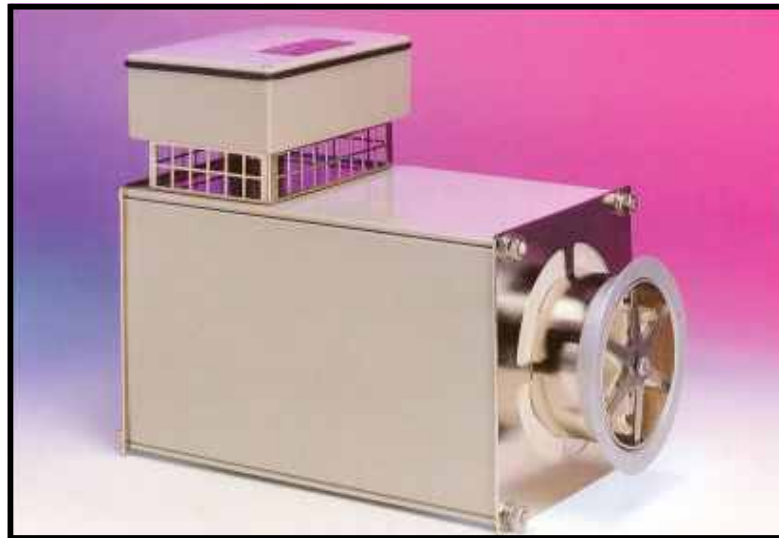

The Model 632 Heater consists of a single element assembly mounted inside a stainless steel tube which is enclosed in an insulated jacket. The jacket allows maximum heat transfer to the airstream while maintaining a low surface temperature. This makes the Model 632 ideal for mounting in vulnerable areas or in enclosures containing other equipment.

The inlet of the 632 is flanged and the outlet is either flanged or provided with a Duct / Hose adapter.

The Model 632 Heater will give an outlet temperature up to 300°C and is available in loadings from 1 to 12kW. The inlet of the 632 can be fitted with a thermal cut-out to protect the element in the event of the airflow becoming restricted. The Model 632 is designed to accept inlet air temperatures up to 250°C.

A variety of temperature controls are available ranging from switching devices to provide fixed loadings through to systems to monitor and regulate the output temperature.

A range of adapters is available to couple the Model 632 with a variety of SECOMAK Fans.

Electrical:

415V or 380V 3 phase

220V or 240V single phase

Other voltages available
with limited loading.

Maximum Outlet Temperature: 300°C

Resistance to Airflow (approx.)

0.43" w.g. at 100 ft³/min

1.70" w.g. at 200 ft³/min

10.30" w.g. at 500 ft³/min

PROCESS AIR HEATERS

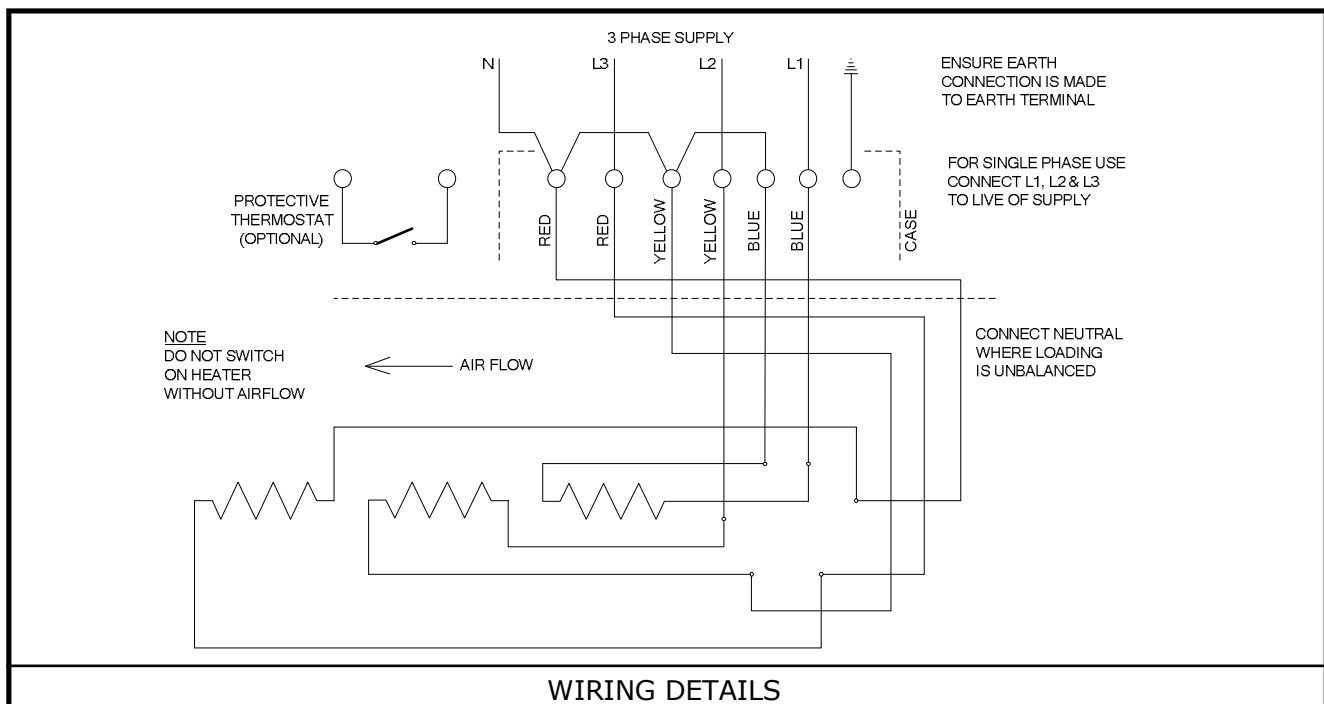
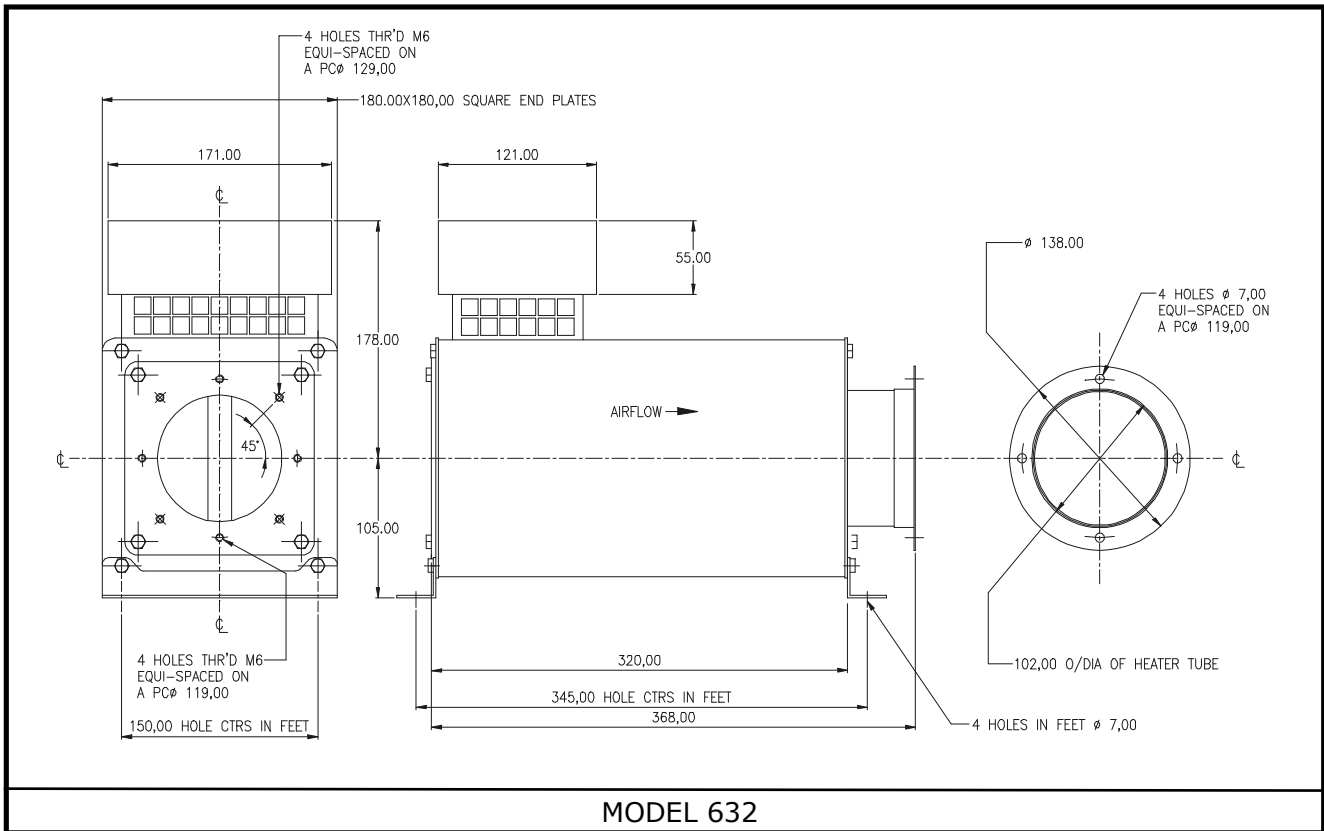

PROCESS AIR HEATERS

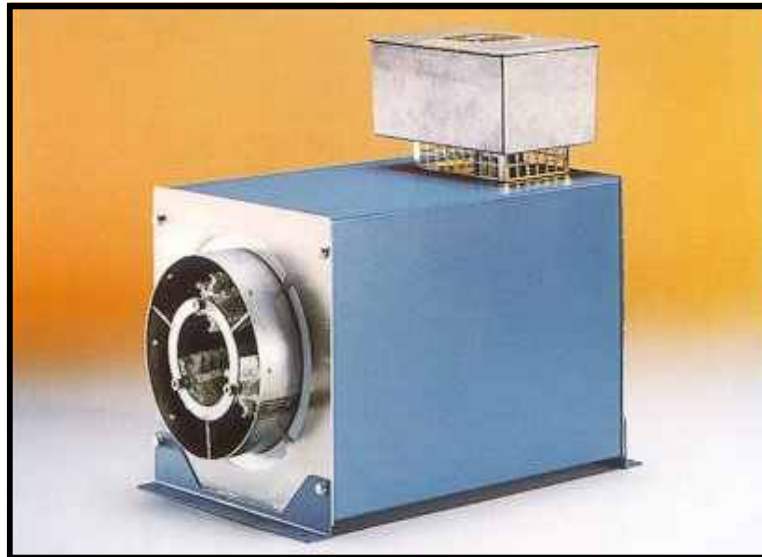

The Model 648 Heater consists of element assemblies mounted inside a stainless steel tube which is enclosed in an insulated jacket. The jacket allows maximum heat transfer to the airstream while maintaining a low surface temperature. This makes the Model 648 ideal for mounting in vulnerable areas or in enclosures containing other equipment.

The inlet of the 648 is flanged and the outlet is either flanged or provided with a Duct / Hose adapter.

The terminal box is manufactured from aluminium and is protected to IP65. Connection is made to each element using DIN rail termination for ease of wiring.

The Model 648 Heater will give an outlet temperature up to 300°C and is available in loadings of 6, 9, 12, 18, 20 or 24kW. The inlet of the 648 can be fitted with a thermal cut-out to protect the element in the event of the airflow becoming restricted.

A variety of temperature controls are available ranging from switching devices to provide fixed loadings through to systems to monitor and regulate the output temperature.

A range of adapters is available to couple the Model 648 with a variety of SECOMAK Fans.

Electrical:

415V or 380V 3 phase

220V or 240V single phase

Other voltages available with limited loading.

Maximum Outlet Temperature: 300°C

Resistance to Airflow (approx.)

0.22" w.g. at 200 ft³/min

3.50" w.g. at 800 ft³/min

10.80" w.g. at 1400 ft³/min

PROCESS AIR HEATERS

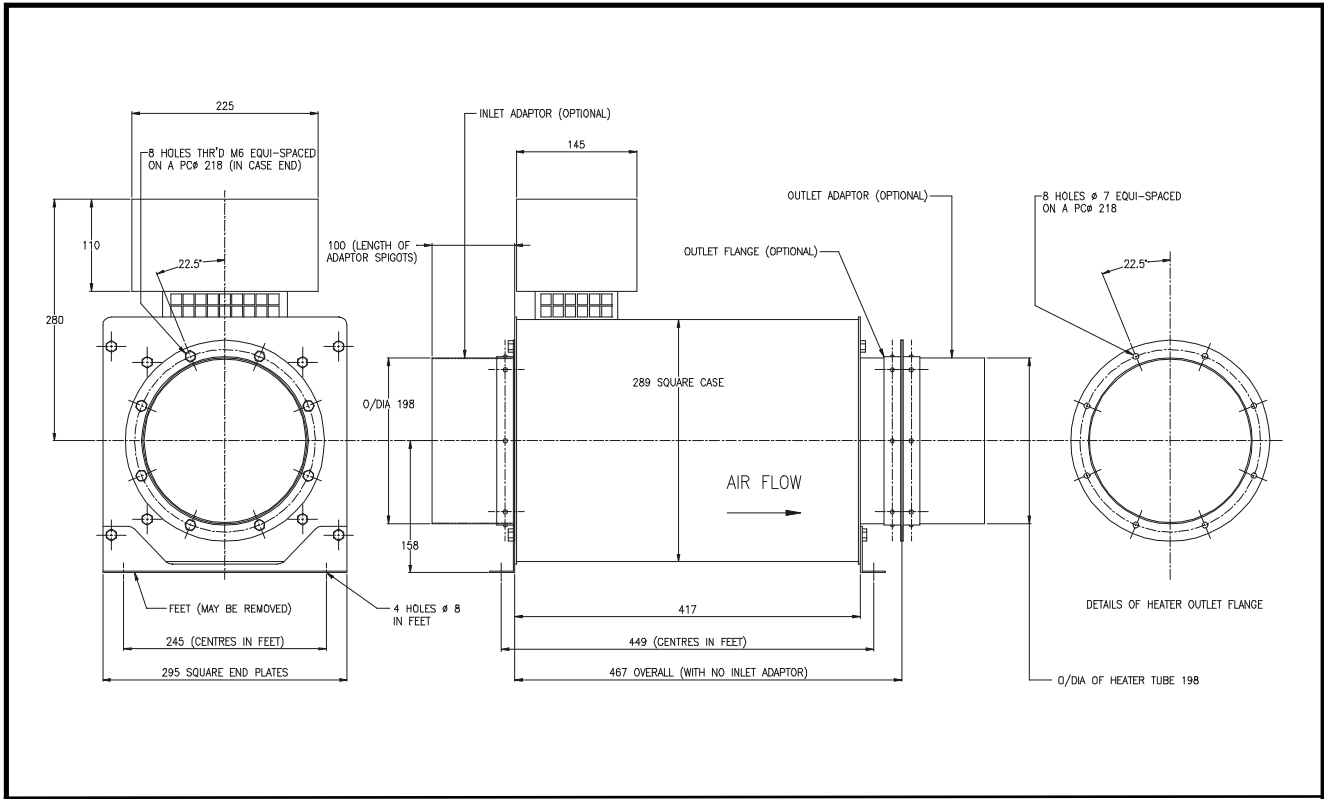

MODEL 648

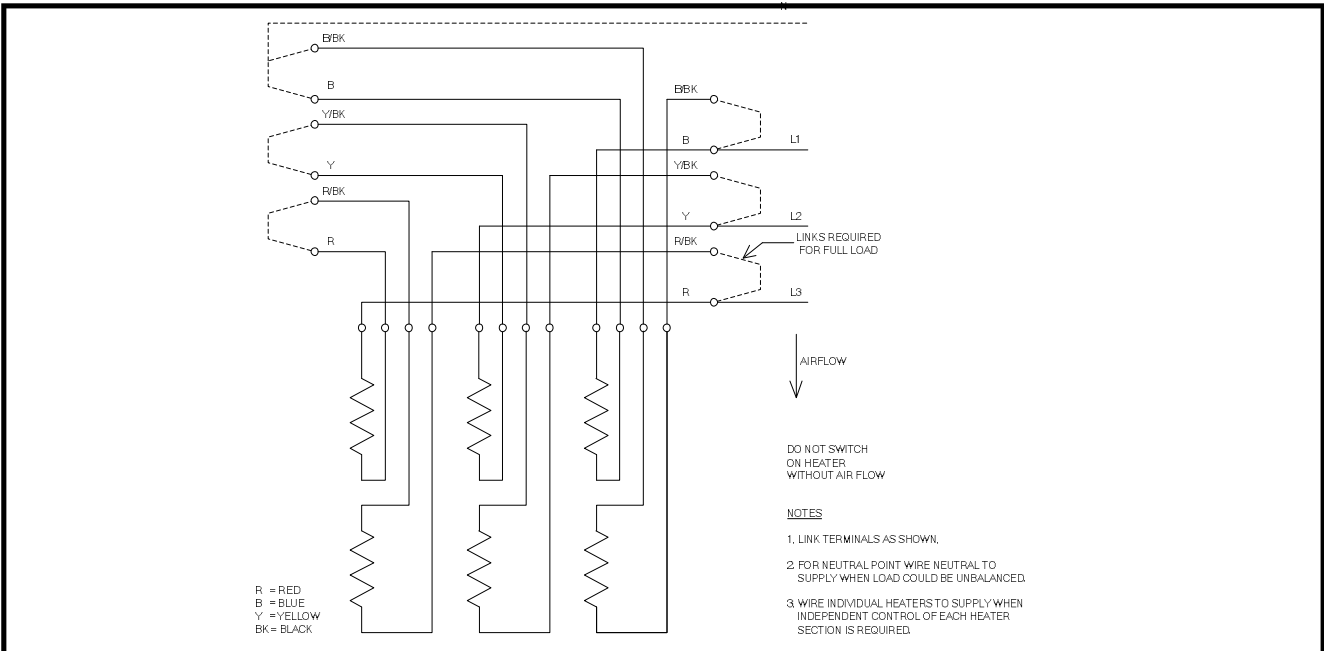

WIRING DETAILS

PROCESS AIR HEATERS

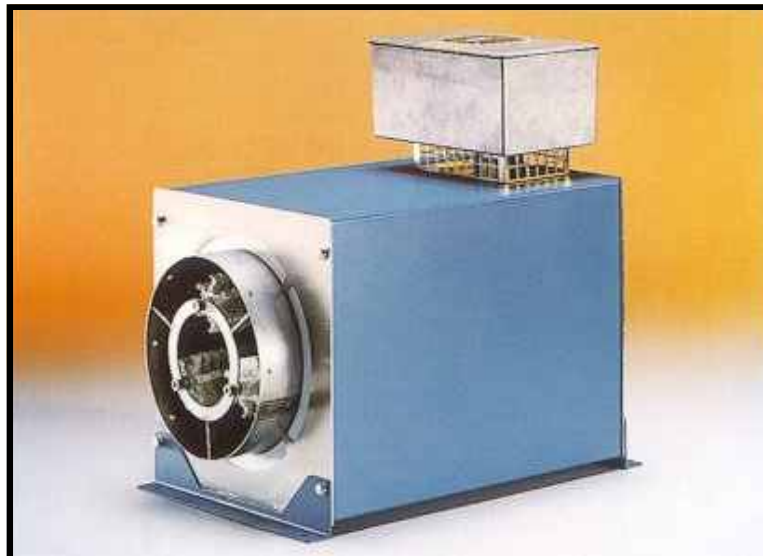

The Model 688 Heater consists of element assemblies mounted inside a stainless steel tube which is enclosed in an insulated jacket. The jacket allows maximum heat transfer to the airstream while maintaining a low surface temperature. This makes the Model 688 ideal for mounting in vulnerable areas or in enclosures containing other equipment.

The inlet of the 688 is flanged and the outlet is either flanged or provided with a Duct / Hose adapter.

The terminal box is manufactured from aluminium and is protected to IP65. Connection is made to each element using DIN rail termination for ease of wiring.

The Model 648 Heater will give an outlet temperature up to 300°C and is available in loadings of 6, 9, 12, 18, 20 or 24kW. The inlet of the 648 can be fitted with a thermal cut-out to protect the element in the event of the airflow becoming restricted.

A variety of temperature controls are available ranging from switching devices to provide fixed loadings through to systems to monitor and regulate the output temperature.

A range of adapters is available to couple the Model 688 with a variety of SECOMAK Fans.

Electrical:

415V or 380V 3 phase

220V or 240V single phase

Other voltages available
with limited loading.

Maximum Outlet Temperature: 300°C

Resistance to Airflow (approx.)

0.22" w.g. at 200 ft³/min

3.50" w.g. at 800 ft³/min

10.80" w.g. at 1400 ft³/min

PROCESS AIR HEATERS

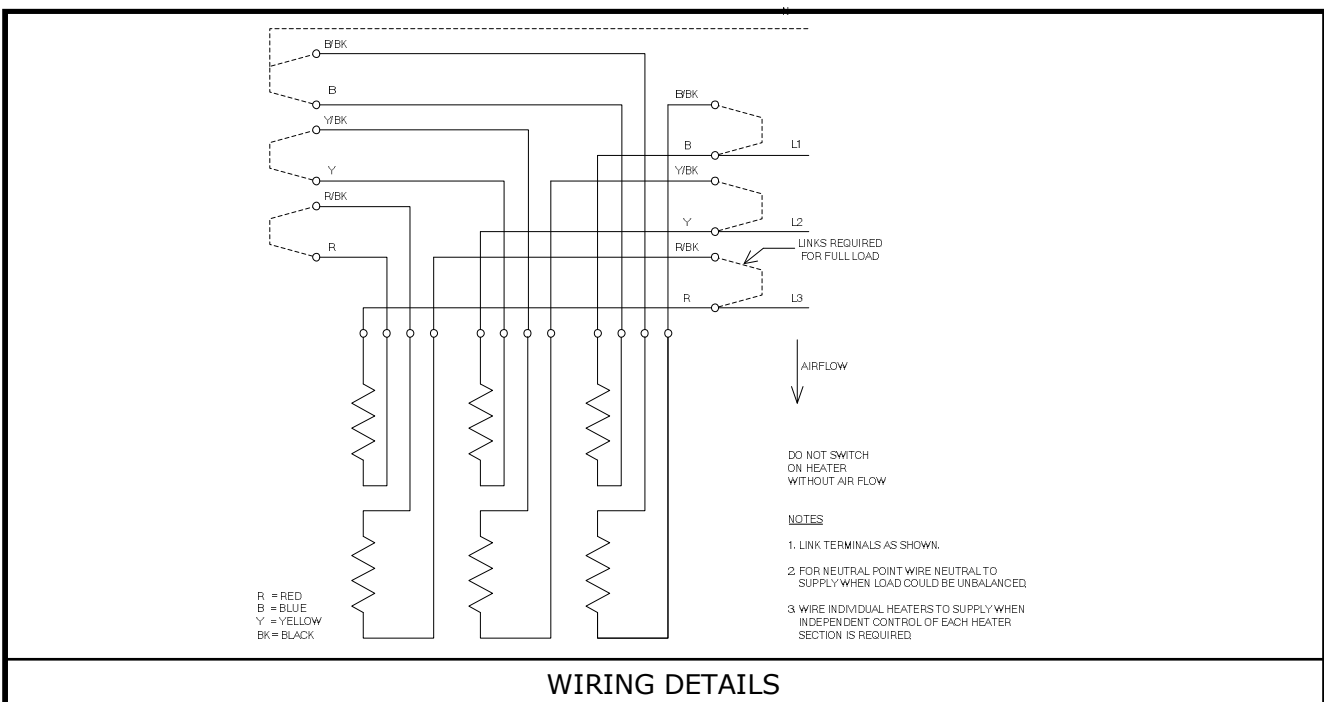
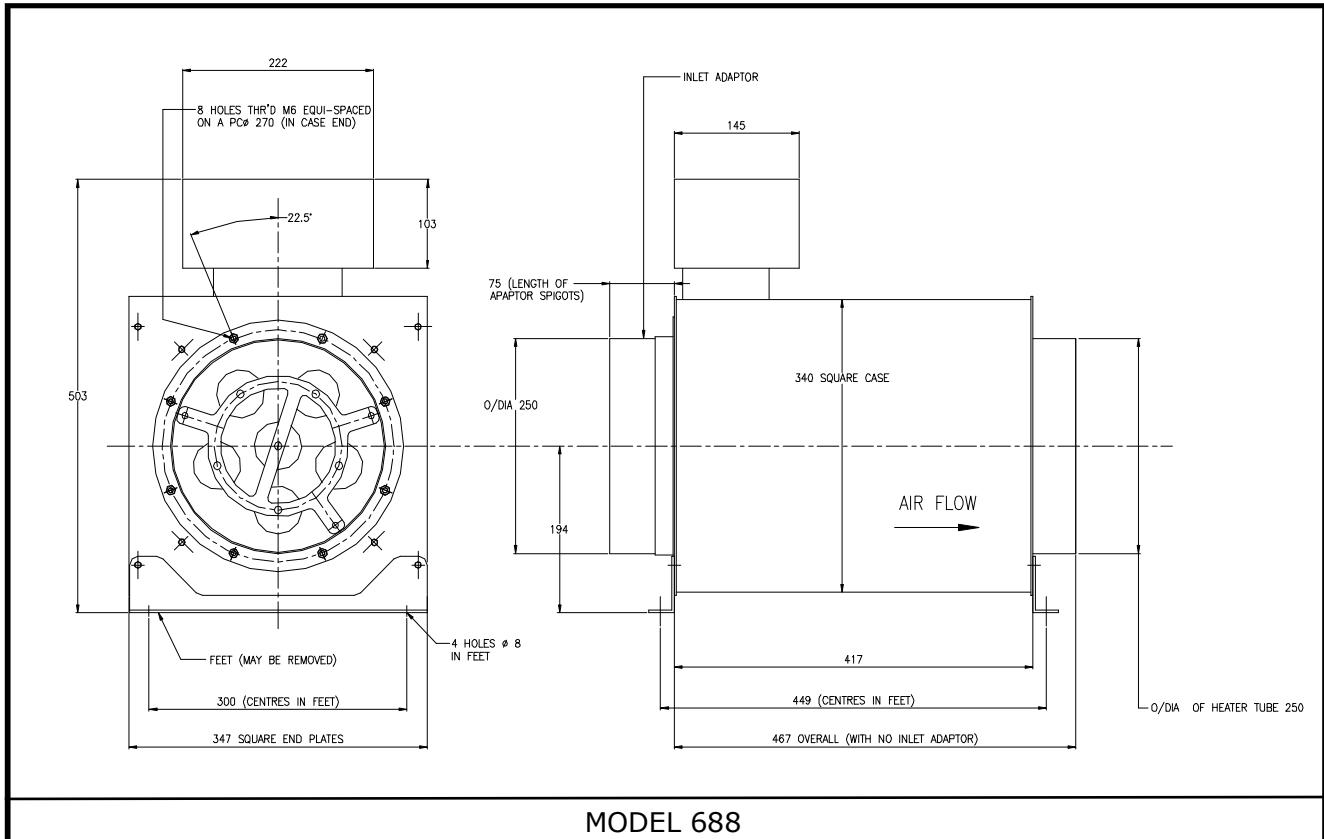

PROCESS AIR HEATERS



Benefits include:

- Ease of installation
- Accurate Temperature Control
- Clean, Dry, Hot Air
- Energy Saving
- Compact and Portable
- Safe Operation
- Flexible Performance
- Conforms to CE, EMC and Low Voltage Regulations

SECOMAK offer a range of packaged process air heater sets. These are complete and ready-to-install systems of fan, electric air heater and temperature control.

Three units are available and are selected by the heat output required.

- Heatpack 9 Up to 9kW
- Heatpack 18 Up to 18kW
- Heatpack 36 Up to 36kW

The fan and heater are mounted on to a base-frame with hose connectors for the outlet (and inlet on Recirculating systems). Braked castors and an adjustable height handle can be fitted if required to produce a mobile unit. Controls consist of a digital set point controller with temperature readout. All or part of the element load is switched using solid state relays to give accurate temperature control. Start and stop buttons are provided and also prevent the heater being operated without the fan. An Over Temperature sensor monitors system performance and shuts down the unit if the temperature rises above a pre-set level. The controls are mounted in a sheet steel IP54 lockable enclosure fitted with an isolator. This can be mounted to the base-frame, wall or other suitable structure. These units have been designed to conform to CE, EMC and Low Voltage regulations. Other combinations of fan and heater would be considered as would variations to the control specification, such as period run-timers, air flow sensors and remote start and stop. The facility to communicate via a computer can also be provided.

PROCESS AIR HEATERS

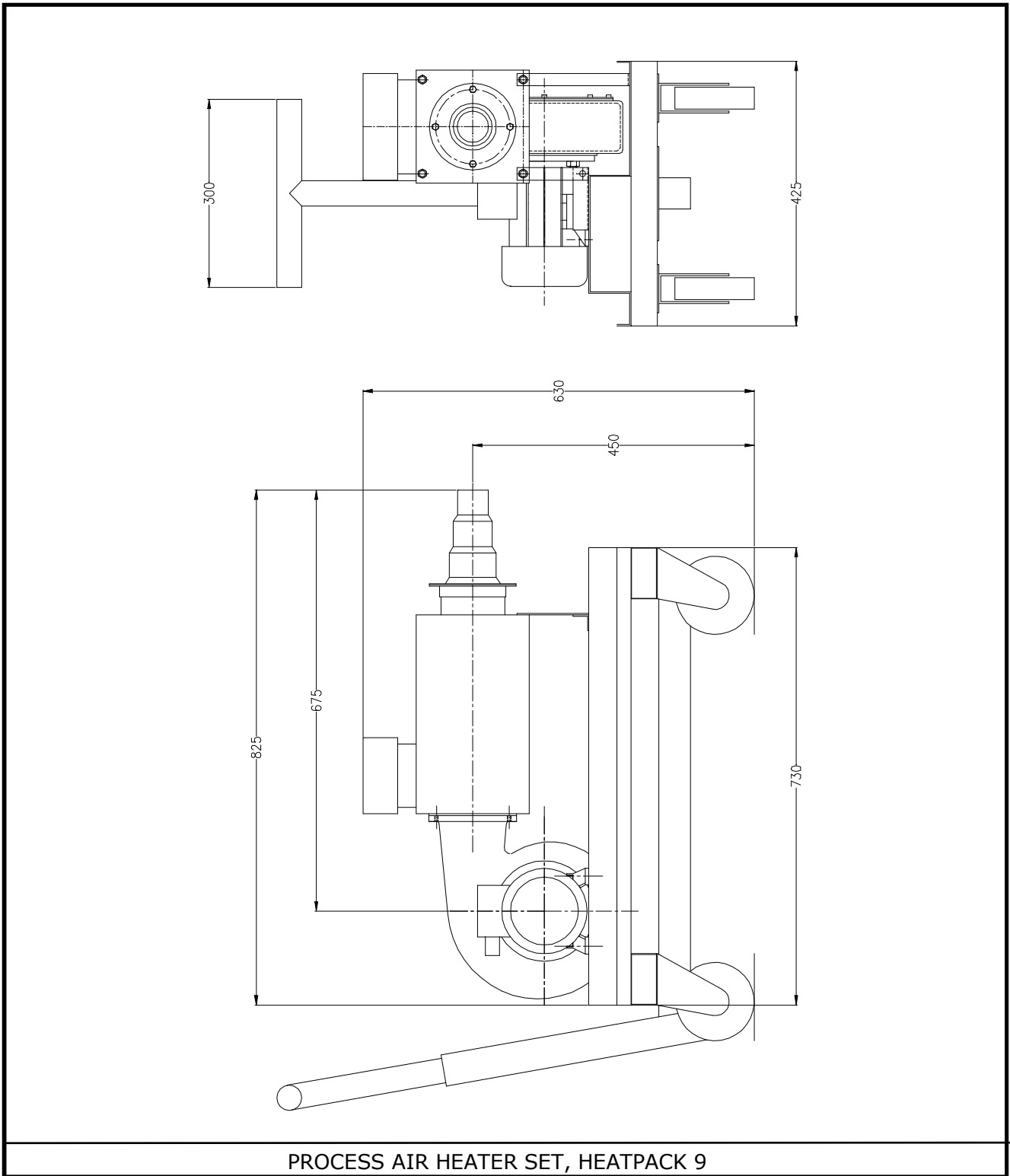

PROCESS AIR HEATER SET, HEATPACK 9

HOT AIR FANS



| Model No. | 513/107 | 513/103 |
|------------------------------------|---------|---------|
| Motor (kW) | 0.37 | 0.37 |
| Phase | 3 | 1 |
| Maximum Running Current (A) | 1.0 | 2.5 |
| Maximum Inlet Air Temperature (°C) | 300 | 300 |
| Weight (kg) | 12 | 13 |
| Noise Level dB(A) * | 73 | 73 |

Current readings are based upon voltages of 400v 3 Phase and 230V 1 Phase.

* Noise levels have been measured at a distance of 1m from the blower, which was fitted with a ducted outlet.

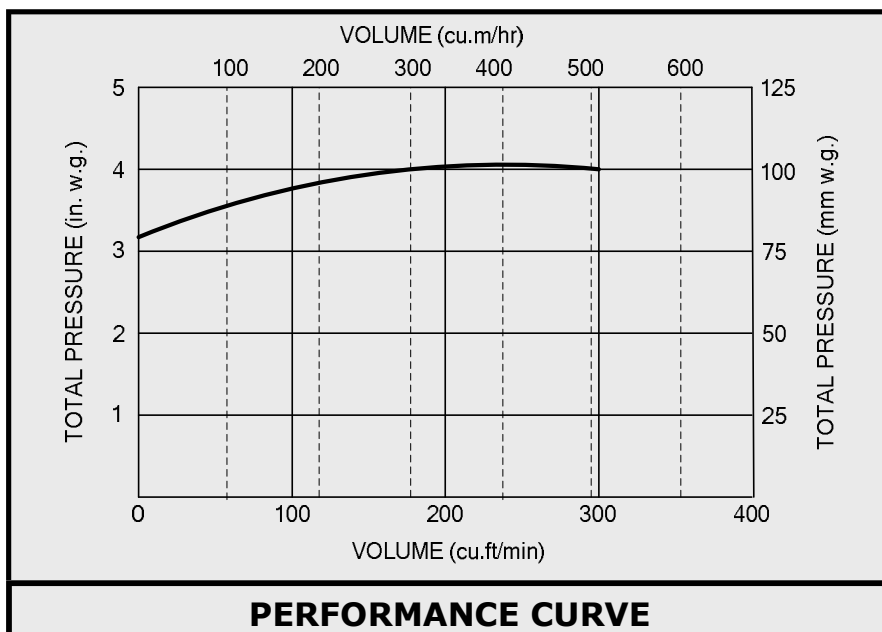

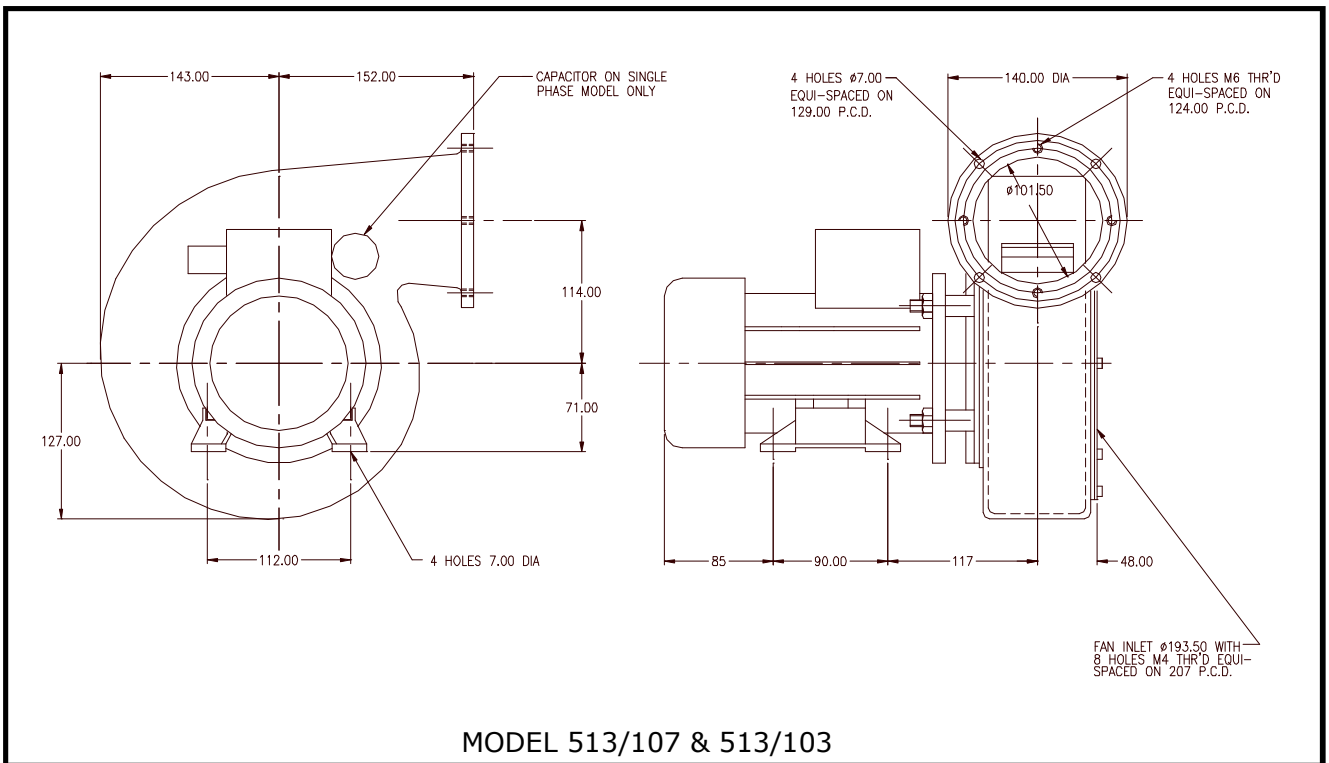
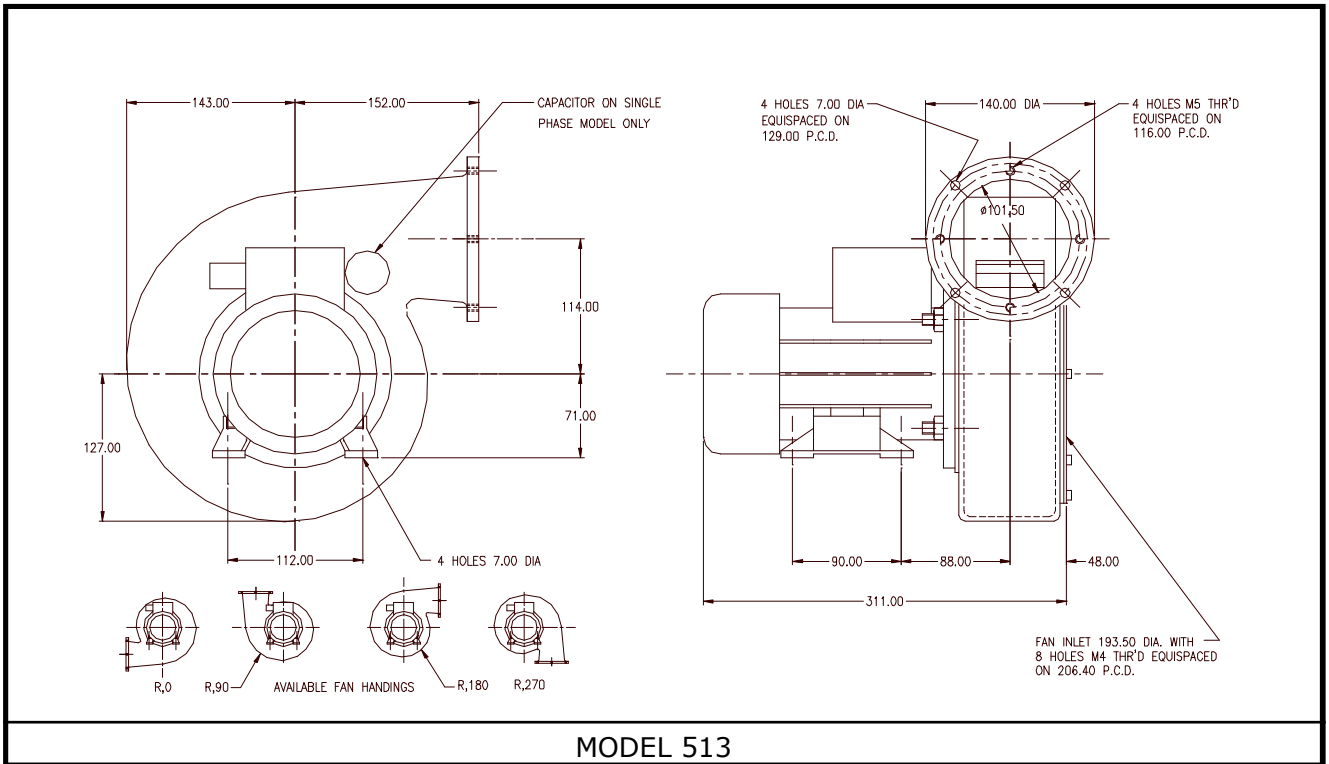



| Model No. | 573 | 573/102 |
|------------------------------------|------|---------|
| Motor (kW) | 0.18 | 0.18 |
| Phase | 1 | 1 |
| Maximum Running Current (A) | 1.0 | 1.0 |
| Maximum Inlet Air Temperature (°C) | 40 | 300 |
| Weight (kg) | 6 | 8 |
| Noise Level dB(A) * | 62 | 62 |

Current readings are based upon voltages of 400v 3 Phase and 230V 1 Phase.

* Noise levels have been measured at a distance of 1m from the blower, which was fitted with a ducted outlet.

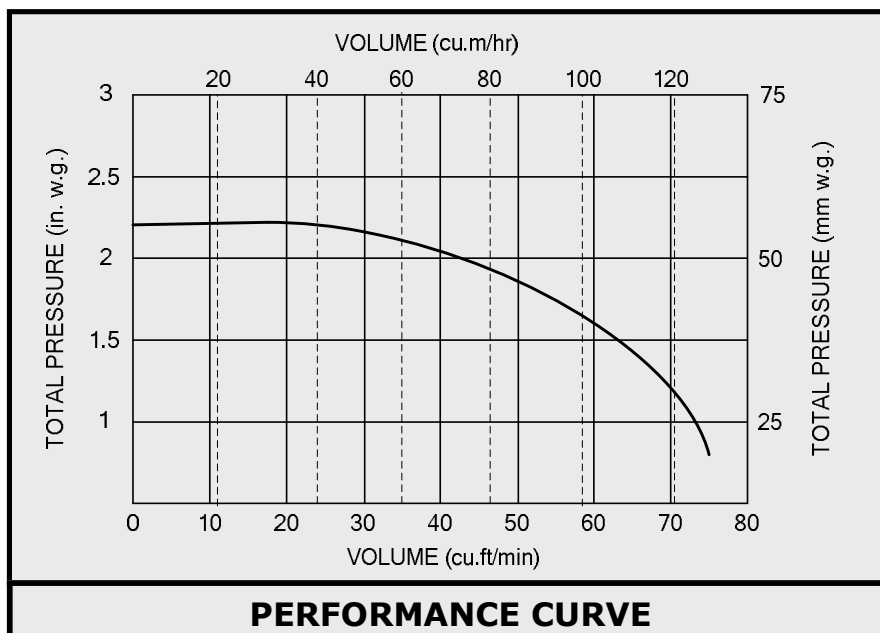

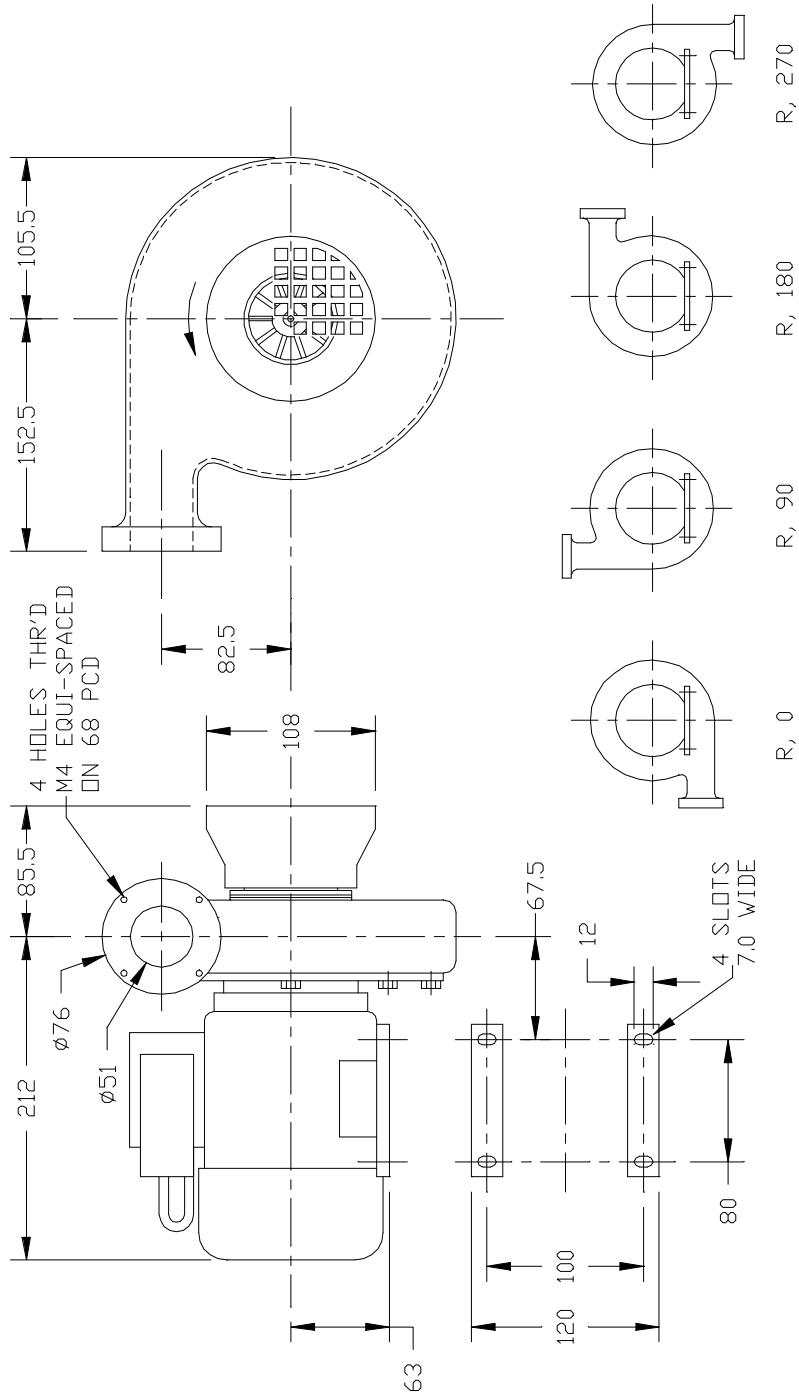

AVAILABLE FAN HANDINGS

MODEL 573



| Model No. | 574 | 574/108 | 574/101 |
|------------------------------------|------|---------|---------|
| Motor (kW) | 0.18 | 0.18 | 0.18 |
| Phase | 1 | 3 | 1 |
| Maximum Running Current (A) | 1.0 | 1.1 | 1.0 |
| Maximum Inlet Air Temperature (°C) | 40 | 40 | 300 |
| Weight (kg) | 8 | 9 | 9 |
| Noise Level dB(A) * | 65 | 65 | 65 |

Current readings are based upon voltages of 400v 3 Phase and 230V 1 Phase.

* Noise levels have been measured at a distance of 1m from the blower, which was fitted with a ducted outlet.

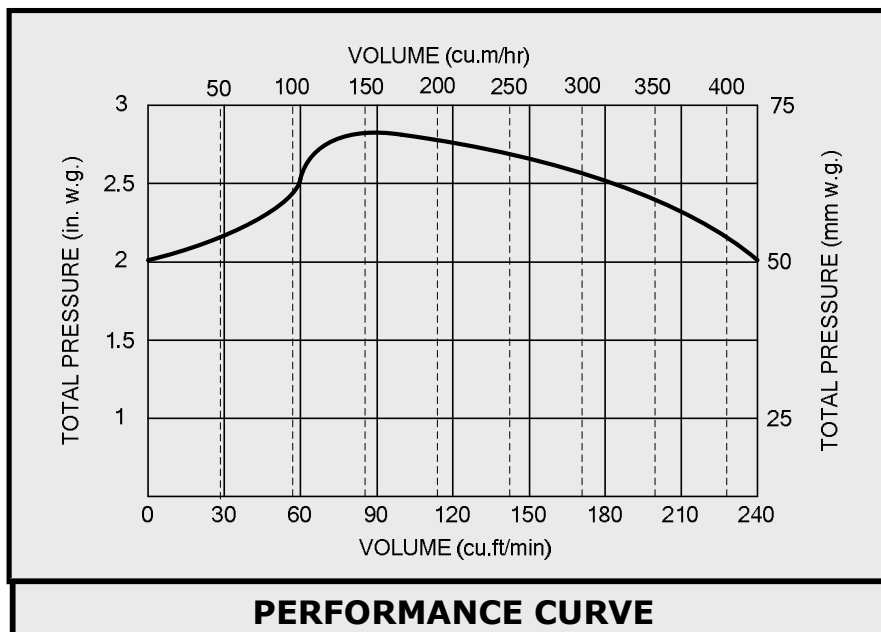

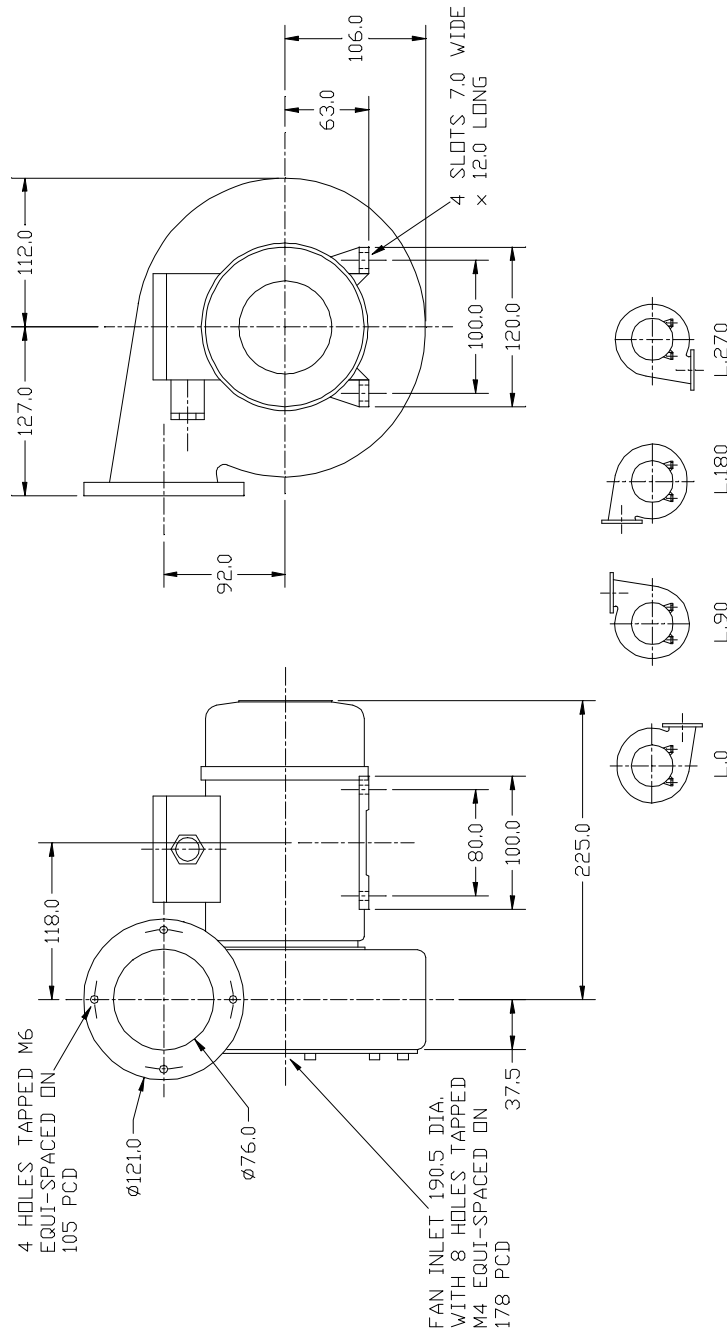

MODEL 574

HOT AIR FANS



| Model No. | 669 | 669 | 669SO | 669SO |
|------------------------------------|------|------|-------|-------|
| Motor (kW) | 0.55 | 0.55 | 0.55 | 0.55 |
| Phase | 1 | 3 | 1 | 3 |
| Maximum Running Current (A) | 3.5 | 1.5 | 3.5 | 1.5 |
| Maximum Inlet Air Temperature (°C) | 40 | 40 | 300 | 300 |
| Weight (kg) | 13.5 | 13.5 | 14 | 14 |
| Noise Level dB(A) * | 71 | 71 | 71 | 71 |

Current readings are based upon voltages of 400v 3 Phase and 230V 1 Phase.

* Noise levels have been measured at a distance of 1m from the blower, which was fitted with a ducted outlet.

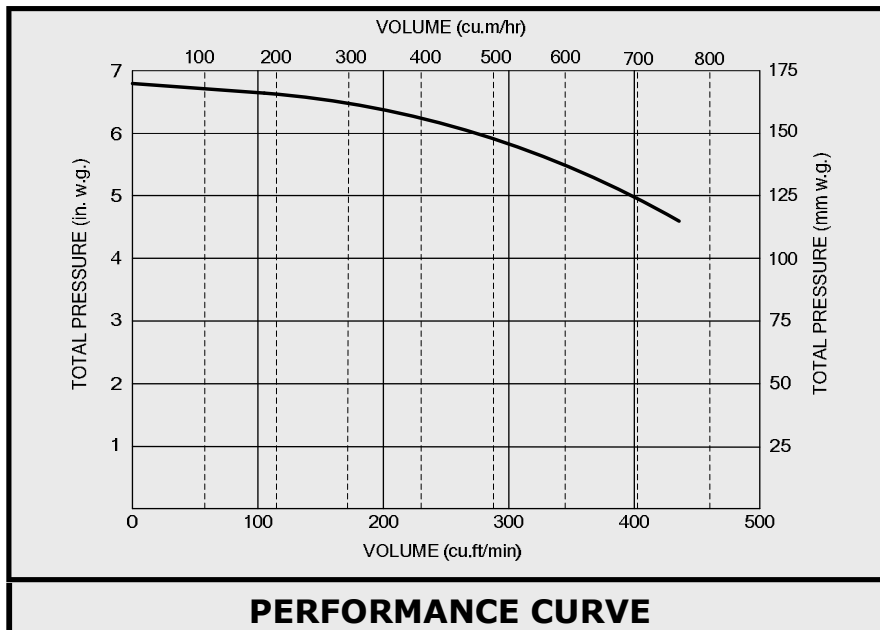

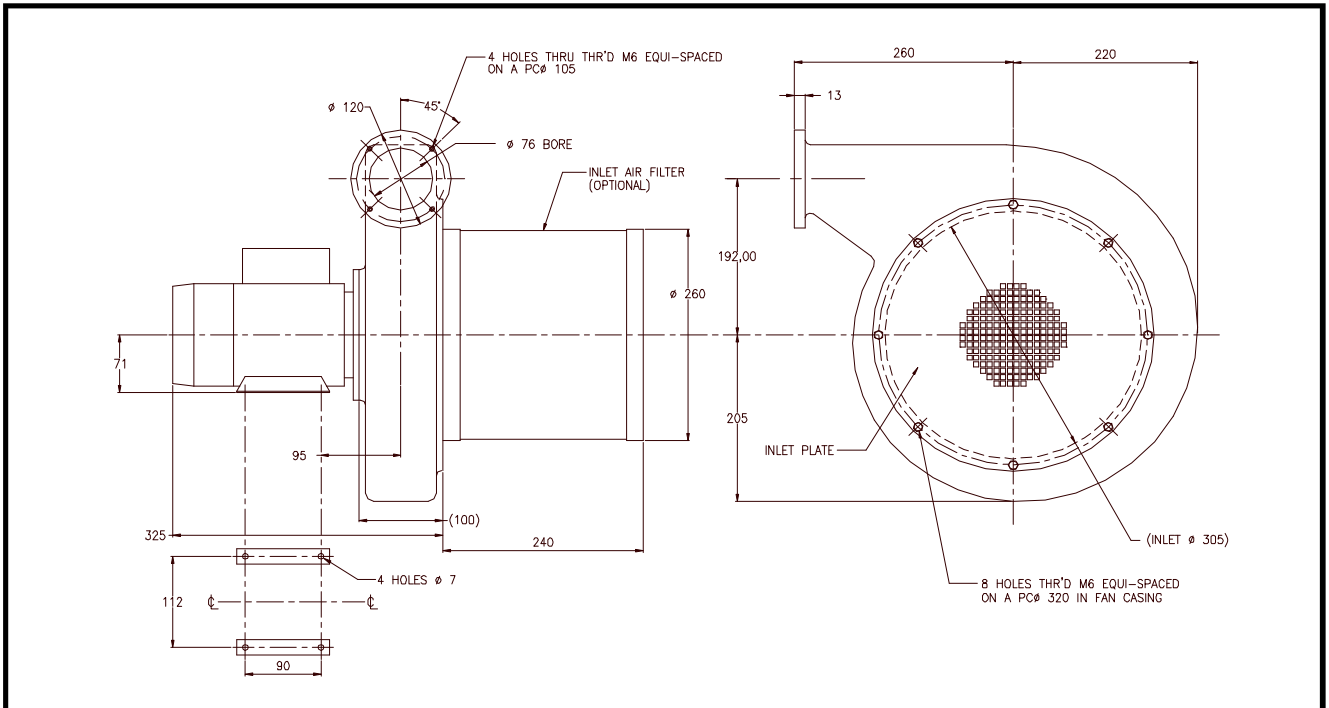

MODEL 669

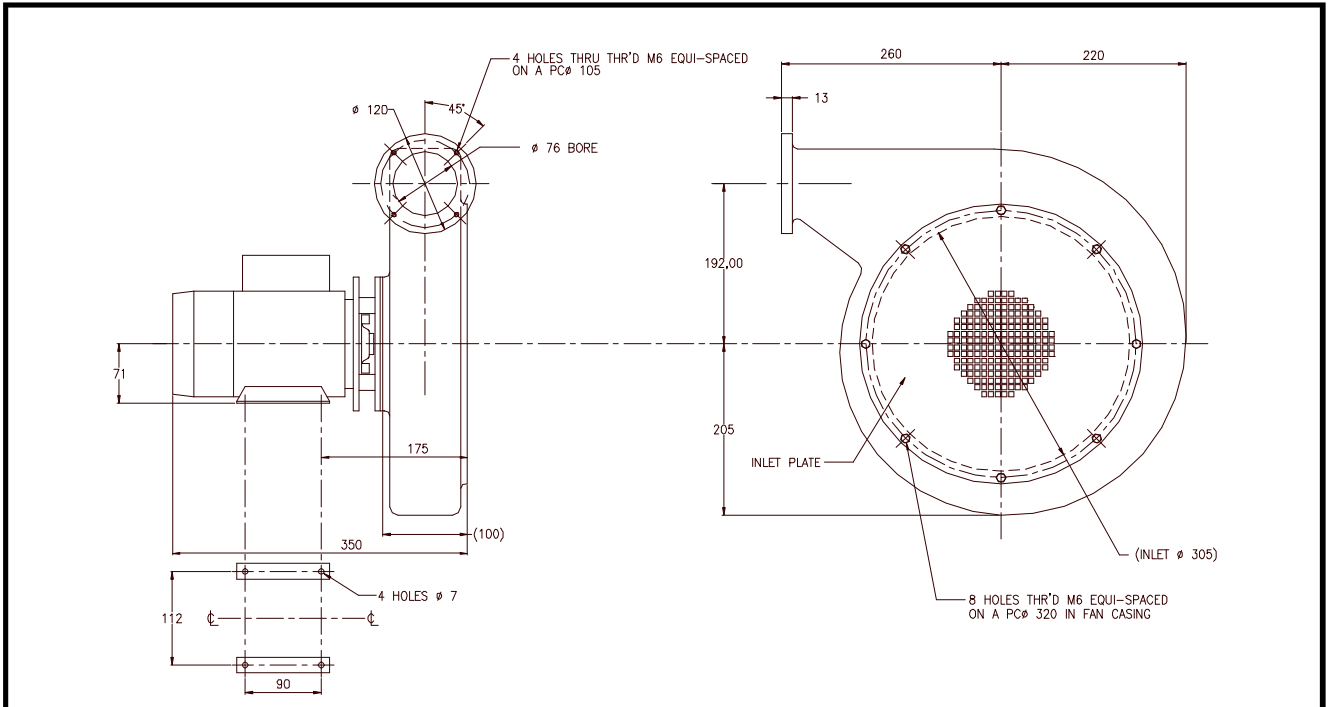

MODEL 669SO



| Model No. | 643 | 643/SO |
|------------------------------------|-----|--------|
| Motor (kW) | 2.2 | 2.2 |
| Voltage (V) | 400 | 400 |
| Phase | 3 | 3 |
| Maximum Running Current (A) | 4.6 | 4.6 |
| Maximum Inlet Air Temperature (°C) | 40 | 300 |
| Weight (kg) | 34 | 34 |
| Noise Level dB(A) * | 88 | 88 |

Current readings are based upon voltages of 400V 3 Phase and 230V 1 Phase.

* Noise levels have been measured at a distance of 1m from the blower, which was fitted with a ducted outlet. In some modes of use these fans may generate high noise levels. It will be necessary to carry out a noise survey after installation.

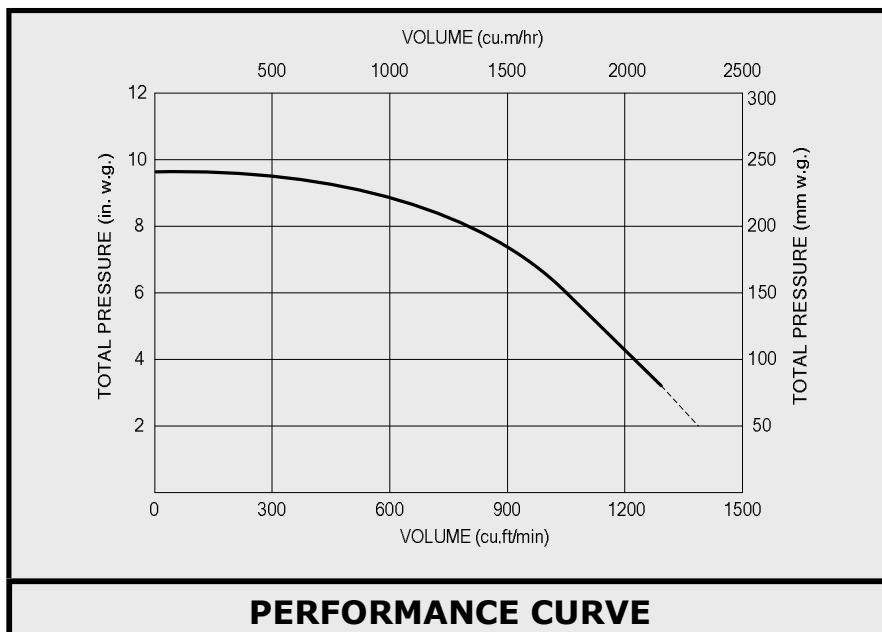

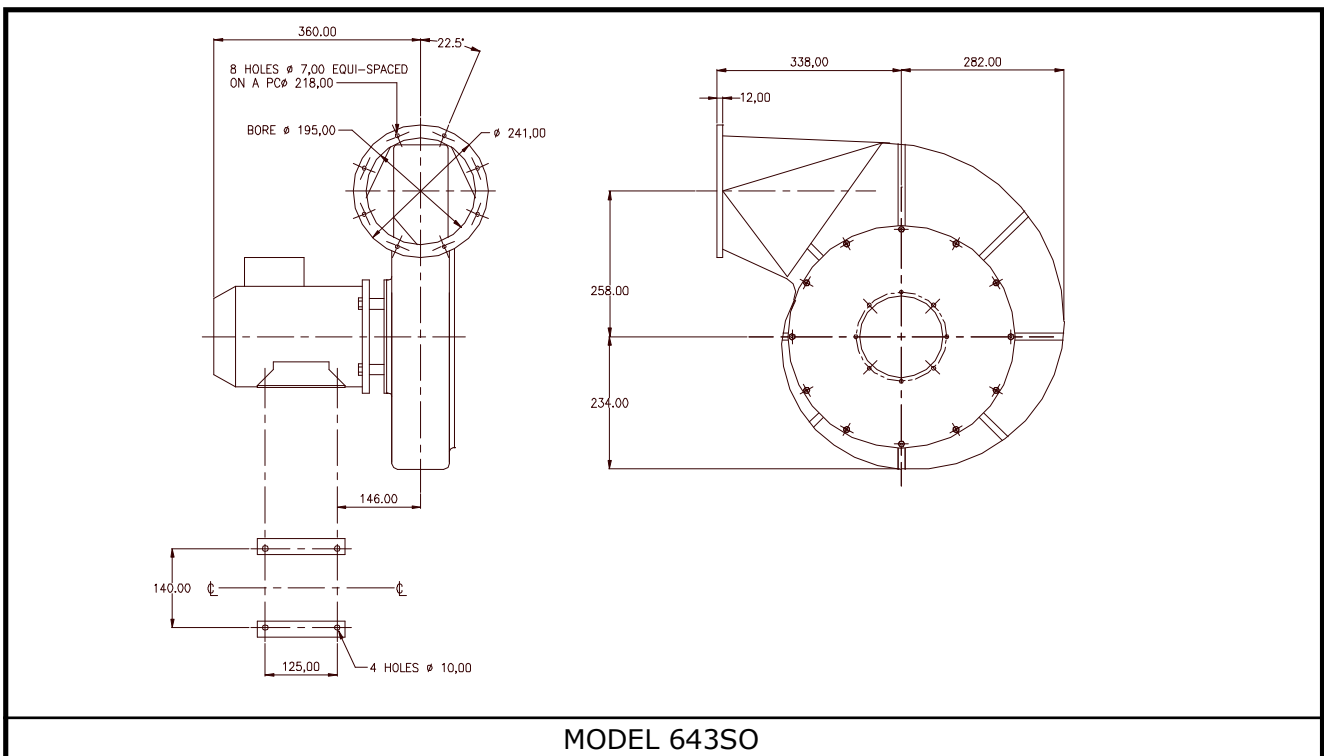
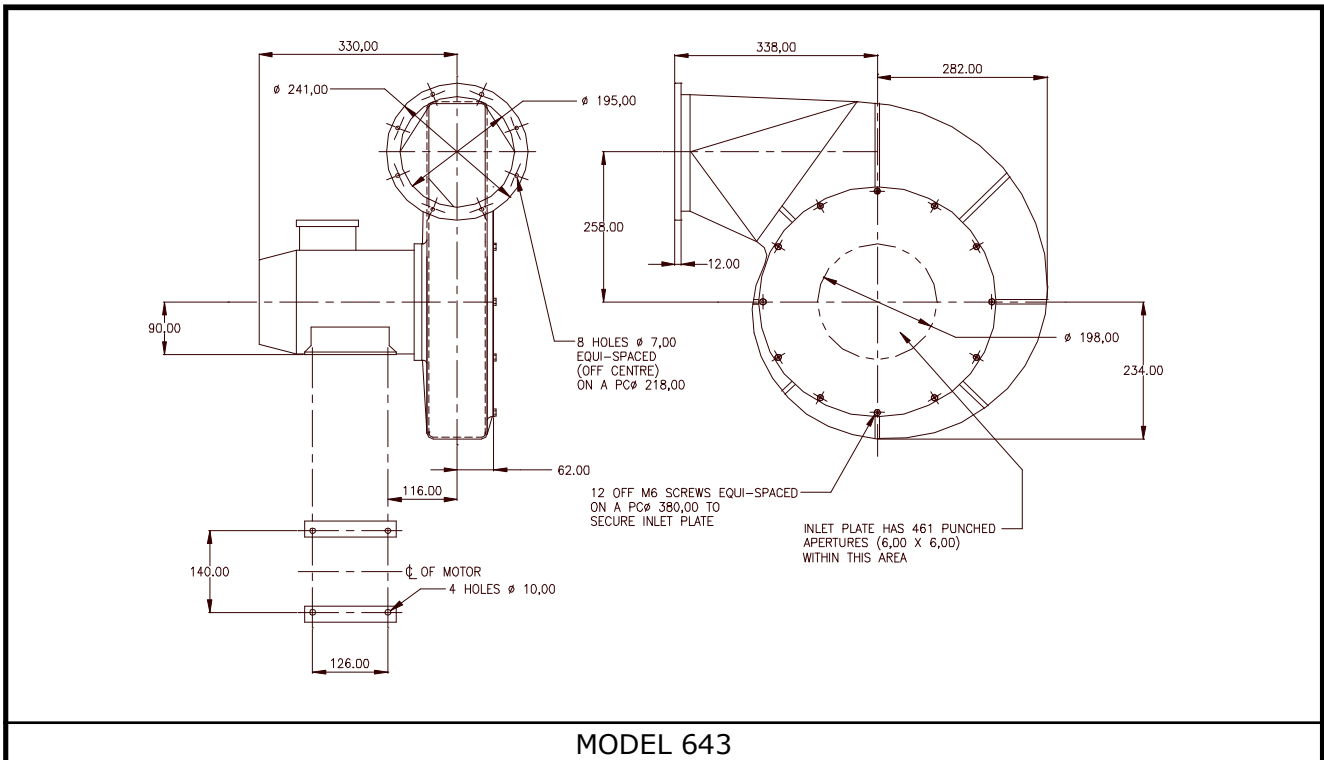

OTHER PRODUCTS



For details of the extensive Secomak product range contact us directly on sales@secomak.com, or your local distributor below:

